

## 1.2 Tonne Electric Vehicle Battery/Engine Lifting Table

### VT-U-DP7



Precision machined safety locks



Safety valve for anti-explosion of hydraulic system



Height limit switch



Adjustable handle



Single sided extendable



Drive-by-wire button



## FEATURES

- Double safety guarantee by hydraulic and mechanical safety locks
- Providing the lowest and highest height limit to ensure safe operation
- With a platform leaned all round and moving horizontally. Provides great assistance for the installation or maintenance for the battery or engine
- Easy to move the platform with the hydraulic lifting trailer
- Capable of lifting a vehicle battery/ engine within 1200kg
- Adjustable handle for easy operation
- Gimbal level to monitor horizontal positioning
- Top fixed/ extendable platforms are made with screw holes for easy installation of a battery or engine fixed kits.

## 1.2 Tonne Electric Vehicle Battery/Engine Lifting Table

### VT-U-DP7

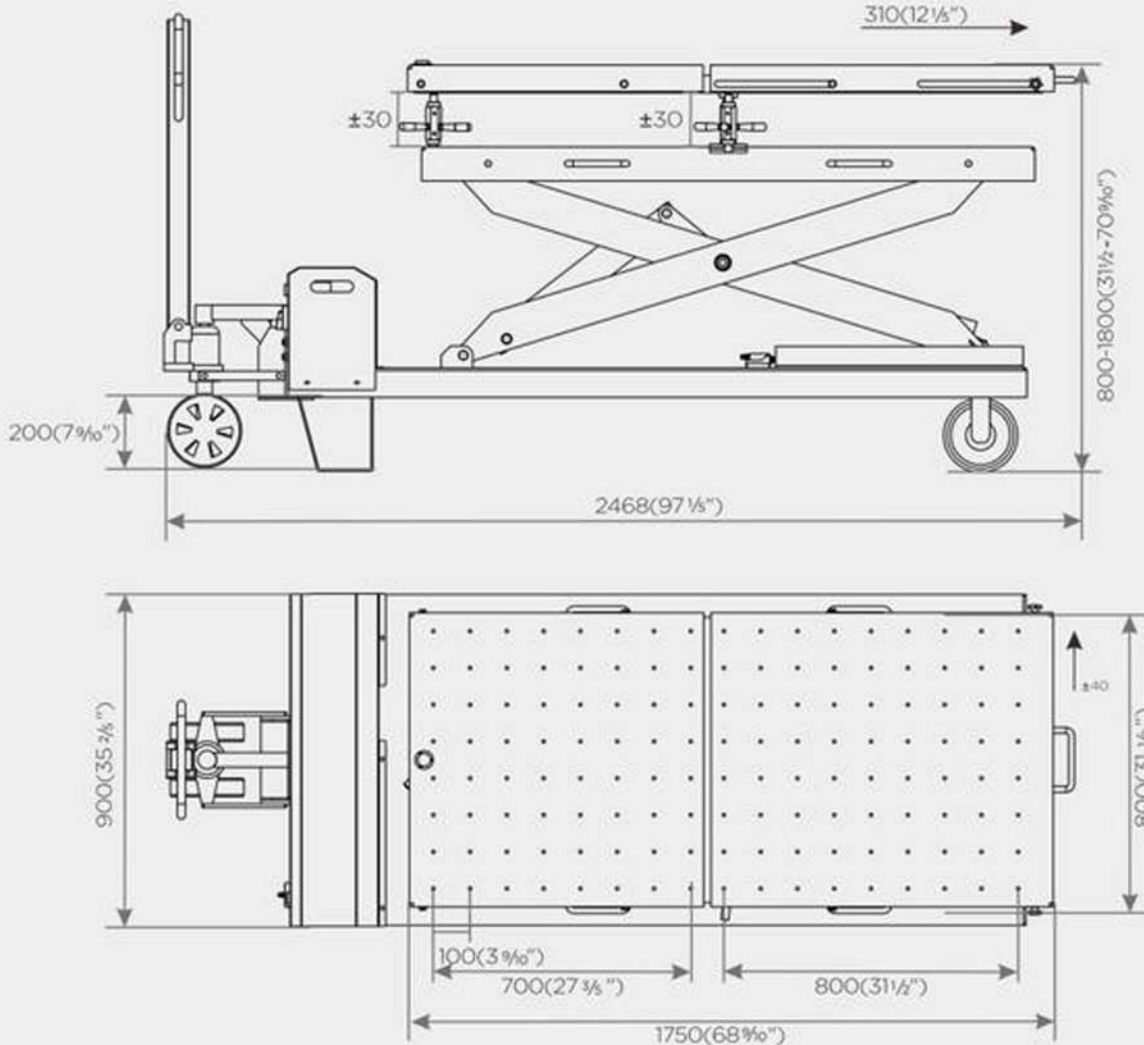

### TECHNICAL DATA

Capacity	1.2 Tonne
Lifting height	1800mm
Min height	800mm
Platform length	1750mm
Platform width	800mm
Power supply	220V 1PH 50Hz 1.5KW